

45% of
Less plastic
compared to
Diffuser 9"
standard

AirTech

9" SL 9" fine bubbles disc diffuser with EPDM membrane and integrated ring nut



Variable according to diffusers density

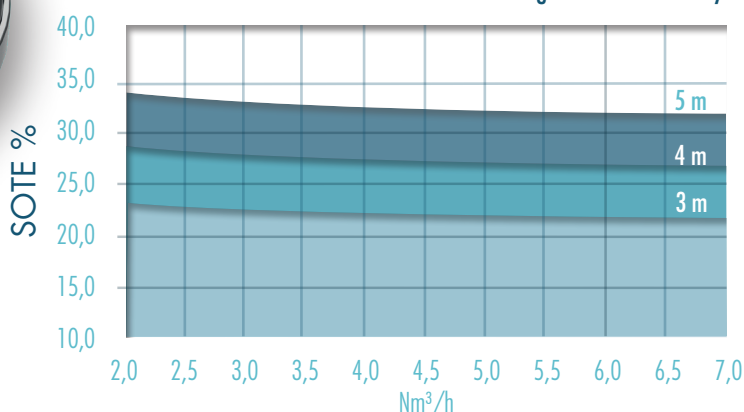

Dimensions

Code	04059
Outer diameter [mm]	257
Threaded connection	3/4" NPT
Weight [Kg]	0,43

Performance

Code	04059
Minimum airflow [Nm³/h]	1,0
Nominal airflow [Nm³/h]	3,5
Maximum airflow [Nm³/h]	7,0
Design airflow range [Nm³/h]	2,0-4,0
* Head losses [cm w.c.]	39,0

* Head losses are calculated at nominal airflow and 4m submergence

Materials

Code	04059
Membrane	EPDM
Holder	PPGF 30%

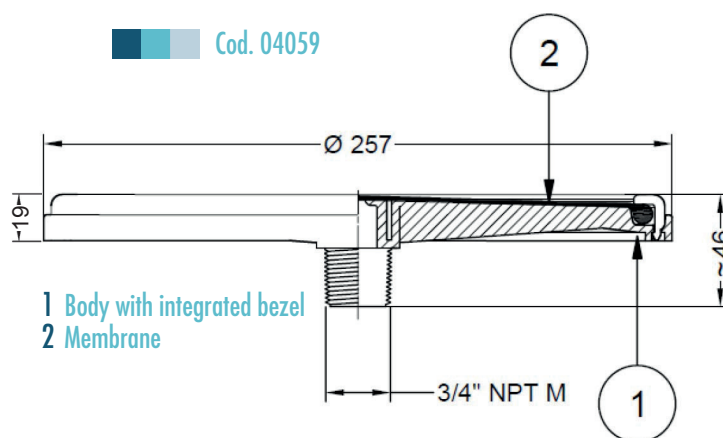

Membrane

Code	04059
Number of slits	>5.000
Perforation [mm]	1,0-1,5
Active surface [m²]	0,0381
Average thickness [mm]	2,2
Tensile strength [Kg/cm²]	>126
Elongation at break [%]	540
Hardness [Shore A]	60
Plasticizer content [%]	< 15

NOTES

SOTE according to ANSI/ASCE-06 (EN 12255-15)
Tolerances on the thickness $\pm 0,2$ mm
Tensile strenght according to ISO 37 type 1
Elongation at break ISO 37 type 1

Data subject to change without notice

WTE SRL Via Re Depaolini,52 • 20015 Parabiago (MI) Italy



Tel. +39 0331 490449 • www.wteitaly.com • info@wteitaly.com